



MODEL 26ASX SPECIFICATION

1.0 General Specifications

There will be furnished one (1) only Grind Hog™ Model 26ASX Comminutor as manufactured by G.E.T. Industries, Inc. Rotation shall be in a clockwise (standard) / counter-clockwise (optional) direction.

1.1 Design Criteria

The comminutor shall be designed to handle the flows indicated below, within the head loss noted.

- (a) hydraulic capacity 20 MGD (75,700m³/day)
- (b) satisfactory operation shall occur under conditions of zero flow
- (c) head loss at peak flow shall not exceed 30 inches (762 mm)
- (d) design shall be such that the flow enters the size reduction and screening device horizontally and exits vertically downward to facilitate the flushing of solids

1.2 Casing and Curb Ring

Shall be:

- (a) of heavy-duty construction and of high quality cast iron
- (b) machined flat and complete with three (3) holes for anchor bolts
- (c) of the open type allowing free access for complete cutting bar and shear bar mechanism maintenance and inspection without dismantling the unit

1.3 Rotating Drum Screen

- (a) heavy-duty Cast Ductile Iron ASTM 536, grade 60-45-18

1.4 Cutting Elements

- (a) replaceable shear bars constructed of high-quality A2 tool-steel shall be attached to the rotating drum. Each shear bar shall be machined from solid bar stock, surface ground to establish exact tolerances
- (b) stationary cutting bars (3), shall be of high-quality 01 tool steel hardened to a minimum of 56 Rockwell C, and shall be reversible, allowing for four (4) sets of cutting edges prior to sharpening or replacement
- (c) all submerged fasteners shall be of stainless steel

1.5 Motor

Submersible, Explosion-proof 3 Hp. (1.12 kw), 1750 RPM _____ volt, 3 phase, 60 HZ, rated for continuous-in-air or submerged in sewage service. Power control cable of 25 ft (7.6 m) included. Class 1, Group C and D, Division 1 Hazardous locations. The motor shall feature:

- **Frame** - rugged cast iron ASTM type A-48, class 30
- **Hardware** - 316 stainless steel
- **Stator Insulation** - specially treated class "F" and "H" non-hydroscopic insulation with multiple dips and brakes. Phase insulation included for inverter duty

G.E.T. INDUSTRIES INC.

Toll Free: 877-213-7418 Email: get@grindhog.com Web: www.grindhog.com

SPECIFICATION cont'd...



- **Rotor** - die cast aluminum, dynamically balanced. Exceeds NEMA limits per MGI - 12.06
- **Shaft** - high strength 416 stainless steel
- **Bearings** - specially adapted for vertical assembly. Both upper and lower bearings are pre-packed and sealed for life with special high temperature grease
- **Cable Entry System** - epoxy sealed butt spliced connect for non-wicking cable entry design
- **Moisture System** - two wire /two probe monitoring system constantly monitors oil chamber and stator housing for moisture
- **Seals** - tandem (dual) shaft seal system working independent of each other. Designed to withstand 100 PSI at all seal locations

1.6 Drive Arrangement

- a) the motor shall be close-coupled to a speed reducer drive, a heavy duty planetary gear of the totally enclosed non-vented type suitable for total submergence during emergencies
- b) double seals on the output shaft shall ensure flood-proof operation through a reduction ratio of 59:1
- c) the cycloidal reducer shall be capable of withstanding shock loads to 500% of its mechanical rating of 11.1 Hp. and be warranted for two (2) years
- d) the drive shall have a minimum full load efficiency of 90% and be pre-lubricated with grease, requiring routing maintenance every 500 to 1,000 hours

A) 'KWIK-LIFT' WET WELL REMOVAL SYSTEM

The Comminutor shall be equipped with a slide rail system which will allow the Grind Hog™ to be removed without entering the wet well. The guide rails shall be 304 schedule 40 stainless steel pipe, 1.5 inches in diameter, and shall be of adequate length as shown on the drawings. Guide rail support shall be 304 stainless steel and shall be mounted to the wet well wall. All attaching hardware shall be of stainless steel and shall be supplied by the contractor.

G.E.T. INDUSTRIES INC.

Toll Free: 877-213-7418 Email: get@grindhog.com Web: www.grindhog.com

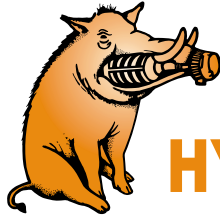

Grind Hog™

HYDRAULIC DATA SHEET IN-CHANNEL MODEL 26A

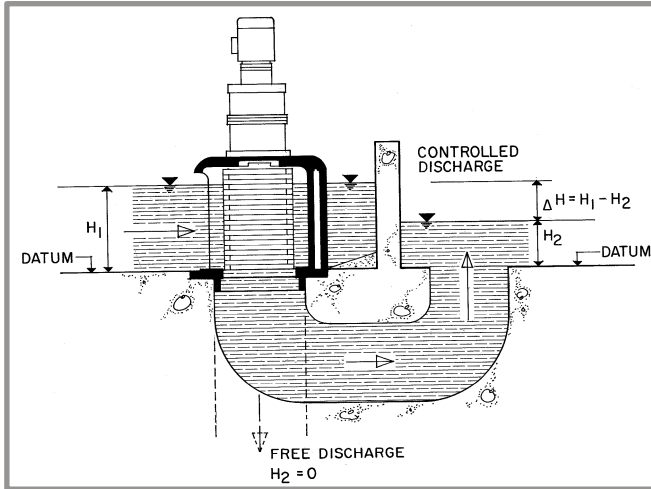

GENERAL DATA

Capacity	0-20 MGD (US)	0-75700 m ³ /day
Drum Diam.	29 in	73.7 cm
Inlet Area	1076 in ²	6942 cm ²
Outlet Area	537 in ²	3456 cm ²
Slot Width	0.470 in	12 mm

HYDRAULIC PERFORMANCE CURVE

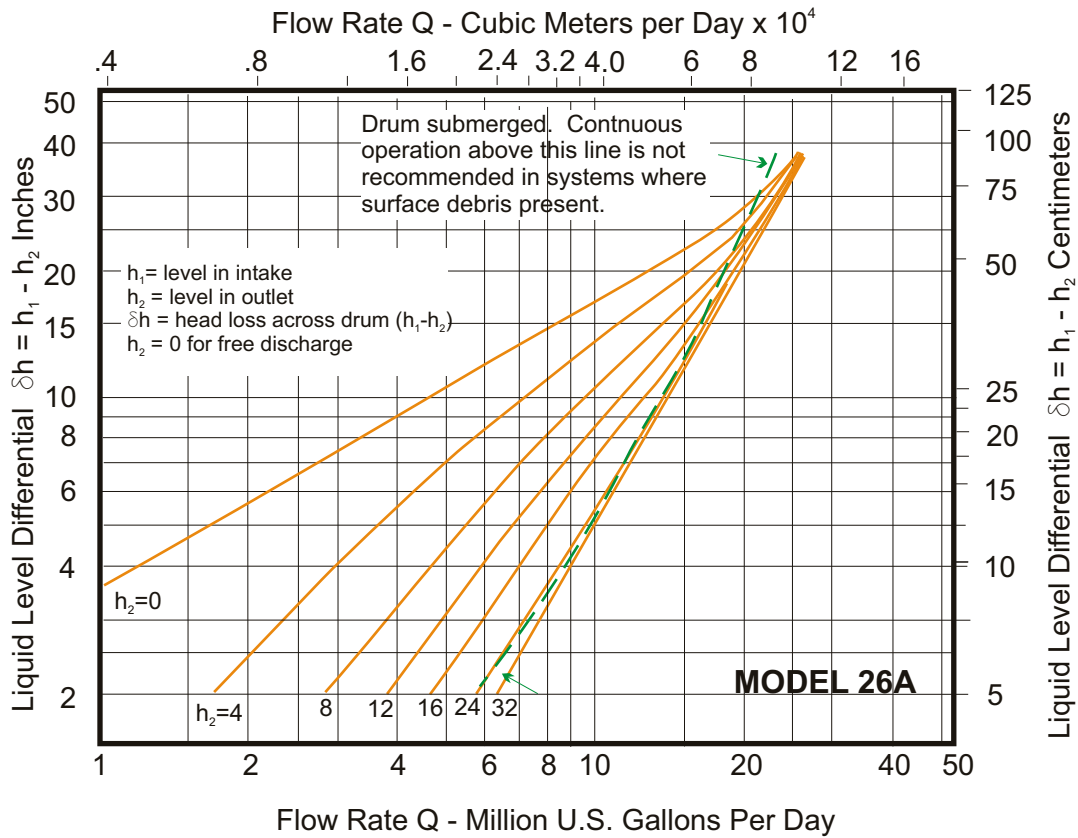



IN-CHANNEL MODEL 26A cont'd...

DESIGN FEATURES

SM-CYCLO® SPEED REDUCERS

- HIGHEST OVERLOAD CAPACITY FOR FREQUENT STOP-START AND SEVERE REVERSING
- SMOOTH, SILENT OPERATION
- EXCEPTIONAL LIFE

Torque transmitting parts roll, don't grind. There is no sliding friction, so output torque/input horsepower efficiency approaches 95%.

STATIONARY CUTTING BAR

- REVERSIBLE-SPARE STANDARD EQUIPMENT
- A2 HIGH QUALITY TOOL STEEL
- HIGH RESISTANCE TO WEAR

VERTICAL "FREE"
OR
"CONTROLLED"
DISCHARGE

CAST DUCTILE IRON SEWAGE SCREEN

- LONG LIFE UNDER ABRASIVE CONDITIONS

ROTATING SHEAR BAR ASSEMBLY

- MACHINED FROM SOLID BARSTOCK
- PRECISE TOLERANCES MAINTAINED.

SUBMERGED FASTENERS OF STAINLESS STEEL

HEAVY DUTY CAST IRON CONSTRUCTION

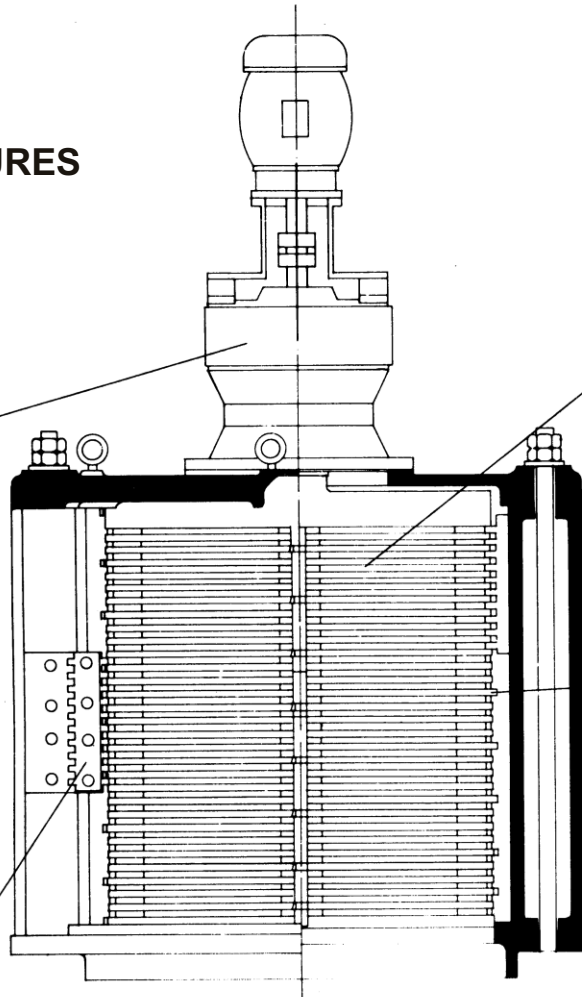

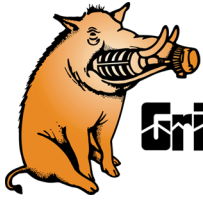

Grind Hog™

MECHANICAL DETAIL

MODEL 26ASX SUMBERSIBLE - EXPLOSION PROOF SERIAL No. _____

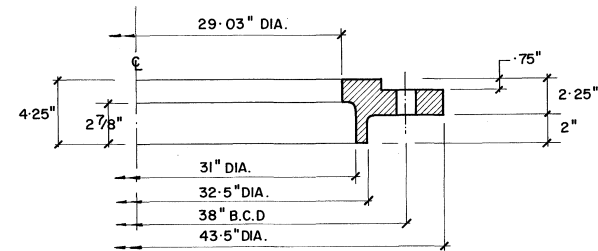
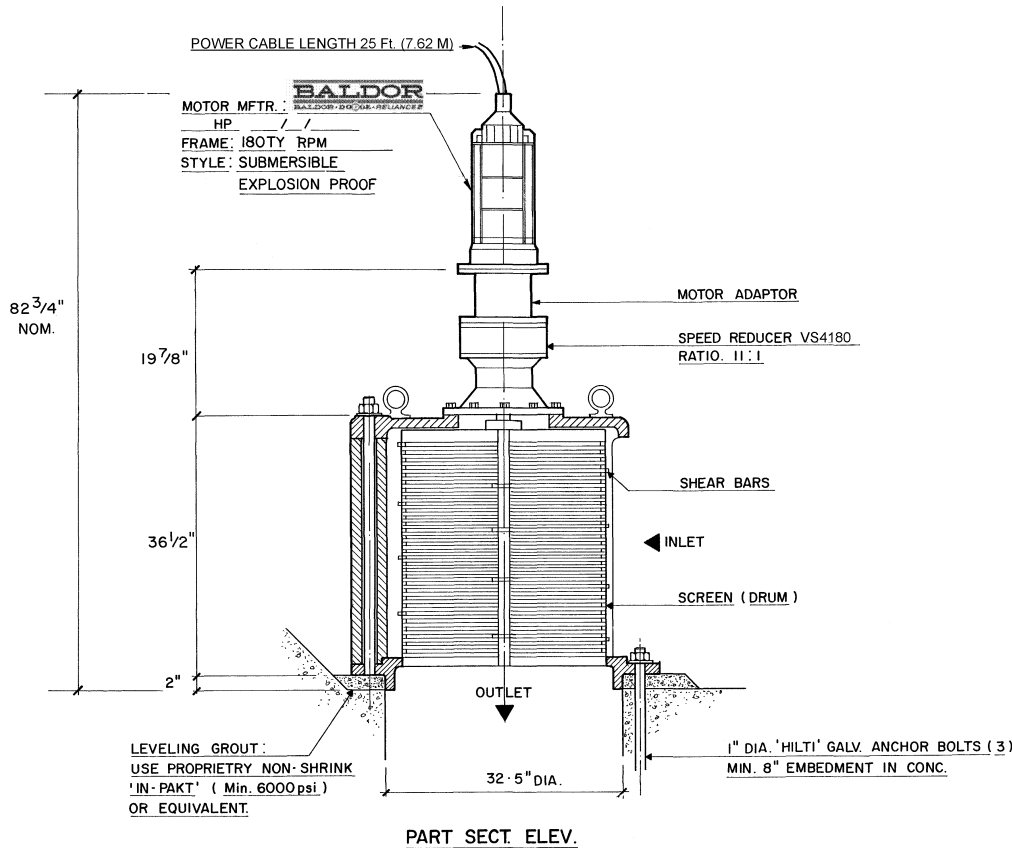

BASE RING DETAIL

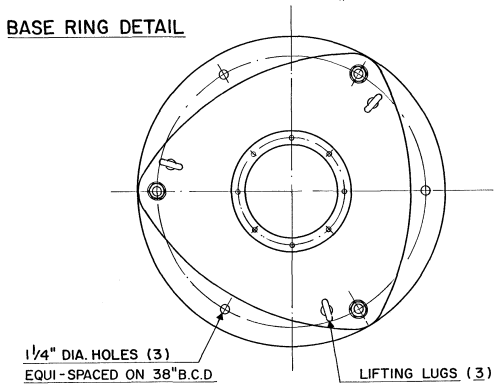

PLAN VIEW OF COMM.

MATERIALS OF CONSTRUCTION & GENERAL ENGINEERING DATA

HOUSING:	GREY IRON	CAPACITY:	20 US (MGD) / 75,000m ³ /day	INLET AREA:	1076 sq in / 6942 cm sq
DRUM (SCREEN):	DUCTILE IRON (ASTM 536 GRADE 60-45-18)	DRUM SPEED:	30 RPM	OUTLET AREA:	537 sq in / 3465 cm sq
SHEAR BARS:	AISI-A2 HIGH ALLOY TOOL STEEL	ROTATION:	CLOCKWISE	DRUM DIAMETER:	29 in / 737cm
CUTTING BARS:	AISI-01 TOOL STEEL REVERSIBLE	SLOT WIDTH:	0.470 in / 12 mm	WEIGHT:	2850 lb / 1293kg
HARDWARE & FASTENERS:	304 STAINLESS STEEL	NO OF SLOTS:	116		
MOTOR MANUFACTURER:	BALDOR	POWER:	____ / ____ / ____	RPM:	1750
SM-CYCLO REDUCER MODEL:	V6170	FRAME:	180TY	FLANGE:	180TY
STYLE: SUB XP C-I-A	HP: 1.5	KW: 2.24		RATIO:	59:1
				RATING:	16.1 HP

REVISIONS	BY	DATE	APP.
G.E.T. INDUSTRIES INC.			
(877) 213-7418			
www.grindhog.com			
TOLERANCES			SCALE
DIMENSIONAL			NTS
FRACTIONAL			DRAWN BY
ANGULAR			APPROVED BY
			WDM
DATE	PROJECT NO.	DRAWING NO.	REV.
Nov. 2006		6 0310	