



MODEL 16A SPECIFICATION

1.0 General Specifications

There will be furnished one (1) only Grind Hog™ Model 16A Comminutor as manufactured by G.E.T. Industries, Inc. Rotation shall be in a clockwise (standard) / counter-clockwise (optional) direction.

1.1 Design Criteria

The comminutor shall be designed to handle the flows indicated below, within the head loss noted.

- (a) hydraulic capacity 3.5 MGD (13200m³/day)
- (b) satisfactory operation shall occur under conditions of zero flow
- (c) head loss at peak flow shall not exceed 15 inches (381 mm)
- (d) design shall be such that the flow enters the size reduction and screening device horizontally and exits vertically downward to facilitate the flushing of solids

1.2 Casing and Curb Ring

Shall be:

- (a) of heavy-duty construction and of high quality cast iron
- (b) machined flat and complete with three (3) holes for anchor bolts
- (c) of the open type allowing free access for complete cutting bar and shear bar mechanism maintenance and inspection without dismantling the unit

1.3 Rotating Drum Screen

- (a) heavy-duty Cast Ductile Iron ASTM 536, grade 60-45-18

1.4 Cutting Elements

- (a) replaceable shear bars constructed of high-quality A2 tool-steel shall be attached to the rotating drum. Each shear bar shall be machined from solid bar stock, surface ground to establish exact tolerances
- (b) stationary cutting bars (3), shall be of high-quality O1 tool steel hardened to a minimum of 56 Rockwell C, and shall be reversible, allowing for four (4) sets of cutting edges prior to sharpening or replacement
- (c) all submerged fasteners shall be of stainless steel

1.5 Motor

TEFC 1.5 Hp. Motor suited to outdoor weatherproof service (IP55) on _____ volt, _____ phase, _____ cycle service. Close-coupled

1.6 Drive Arrangement

- a) the motor shall be close-coupled to a speed reducer drive, a heavy duty planetary gear of the totally enclosed non-vented type suitable for total submergence during emergencies
- b) double seals on the output shaft shall ensure flood-proof operation through a reduction ratio of 59:1

G.E.T. INDUSTRIES INC.

Toll Free: 877-213-7418 Email: get@grindhog.com Web: www.grindhog.com

SPECIFICATION cont'd...



- c) the cycloidal reducer shall be capable of withstanding shock loads to 500% of its mechanical rating of 7.72 Hp. and be warranted for two (2) years
- d) the drive shall have a minimum full load efficiency of 90% and be pre-lubricated with grease, requiring routing maintenance every 500 to 1,000 hours

A) 'KWIK-LIFT' WET WELL REMOVAL SYSTEM

The Comminutor shall be equipped with a slide rail system which will allow the Grind Hog™ to be removed without entering the wet well. The guide rails shall be 304 schedule 40 stainless steel pipe, 1.5 inches in diameter, and shall be of adequate length as shown on the drawings. Guide rail support shall be 304 stainless steel and shall be mounted to the wet well wall. All attaching hardware shall be of stainless steel and shall be supplied by the contractor.

G.E.T. INDUSTRIES INC.

Toll Free: 877-213-7418 Email: get@grindhog.com Web: www.grindhog.com

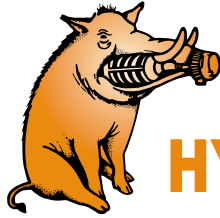

Grind Hog™

HYDRAULIC DATA SHEET IN-CHANNEL MODEL 16A

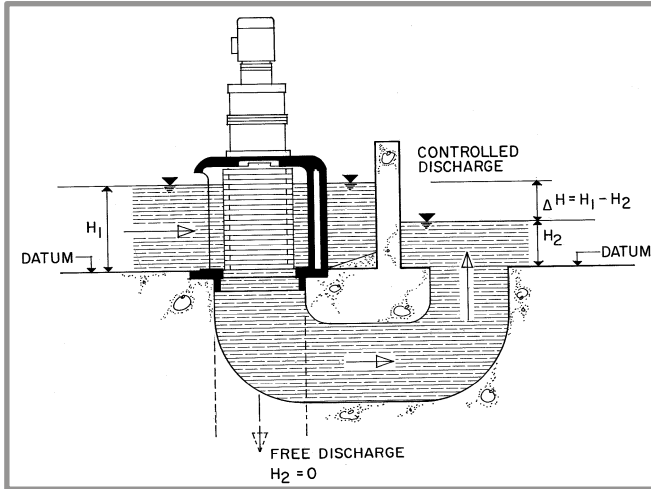

GENERAL DATA

Capacity	0-3.5 MGD (US)	0-13200 m ³ /day
Drum Diam.	14.5 in	36.8 cm
Inlet Area	202 in ²	1303 cm ²
Outlet Area	121 in ²	780.6 cm ²
Slot Width	0.470 in	12 mm

HYDRAULIC PERFORMANCE CURVE

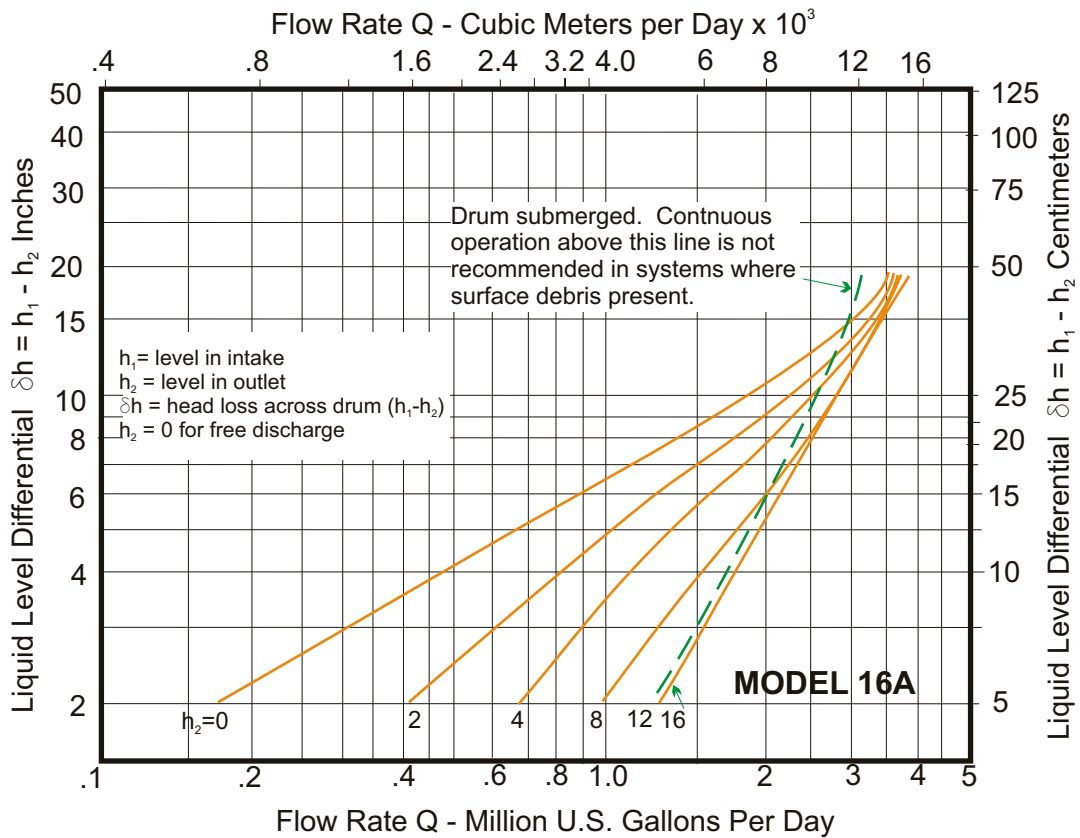

G.E.T. Industries Inc.

Toll Free: (877) 213-7418

E-mail: get@grindhog.com ♦ Web: www.grindhog.com



IN-CHANNEL MODEL 16A cont'd...

DESIGN FEATURES

SM-CYCLO® SPEED REDUCERS

- HIGHEST OVERLOAD CAPACITY FOR FREQUENT STOP-START AND SEVERE REVERSING
- SMOOTH, SILENT OPERATION
- EXCEPTIONAL LIFE

Torque transmitting parts roll, don't grind. There is no sliding friction, so output torque/input horsepower efficiency approaches 95%.

STATIONARY CUTTING BAR

- REVERSIBLE-SPARE STANDARD EQUIPMENT
- A2 HIGH QUALITY TOOL STEEL
- HIGH RESISTANCE TO WEAR

VERTICAL "FREE"
OR
"CONTROLLED"
DISCHARGE

CAST DUCTILE IRON SEWAGE SCREEN

- LONG LIFE UNDER ABRASIVE CONDITIONS

ROTATING SHEAR BAR ASSEMBLY

- MACHINED FROM SOLID BARSTOCK
- PRECISE TOLERANCES MAINTAINED.

SUBMERGED FASTENERS OF STAINLESS STEEL

HEAVY DUTY CAST IRON CONSTRUCTION

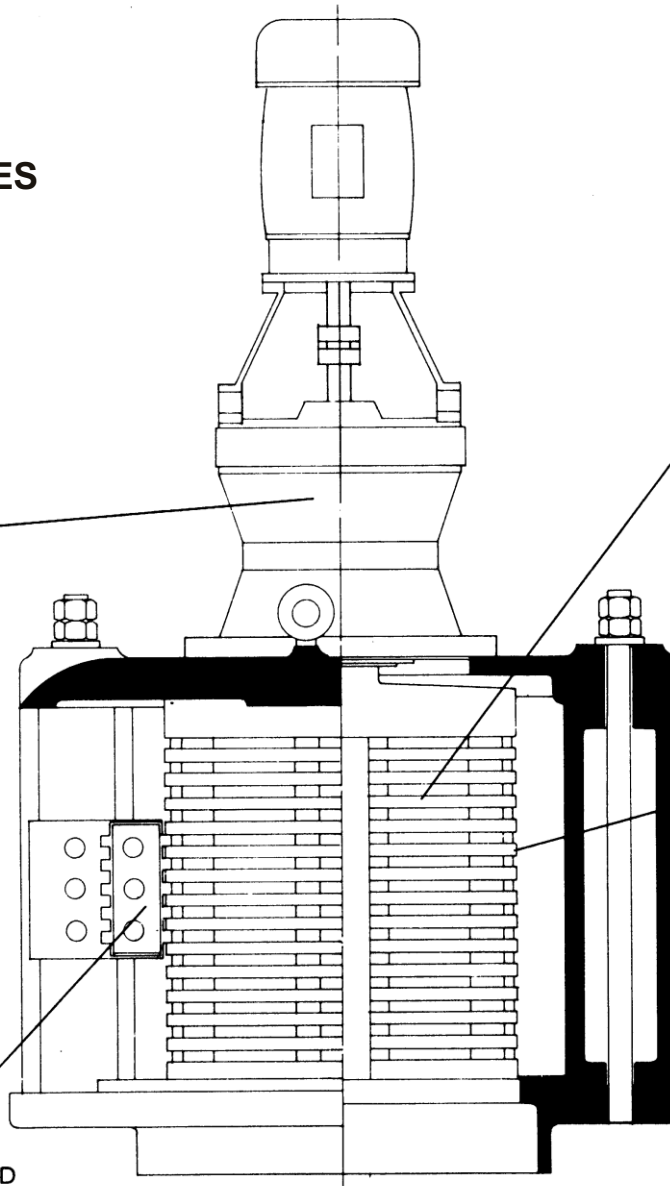

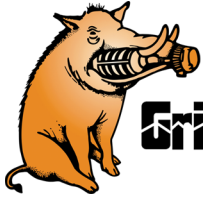

Grind Hog™

MECHANICAL DETAIL

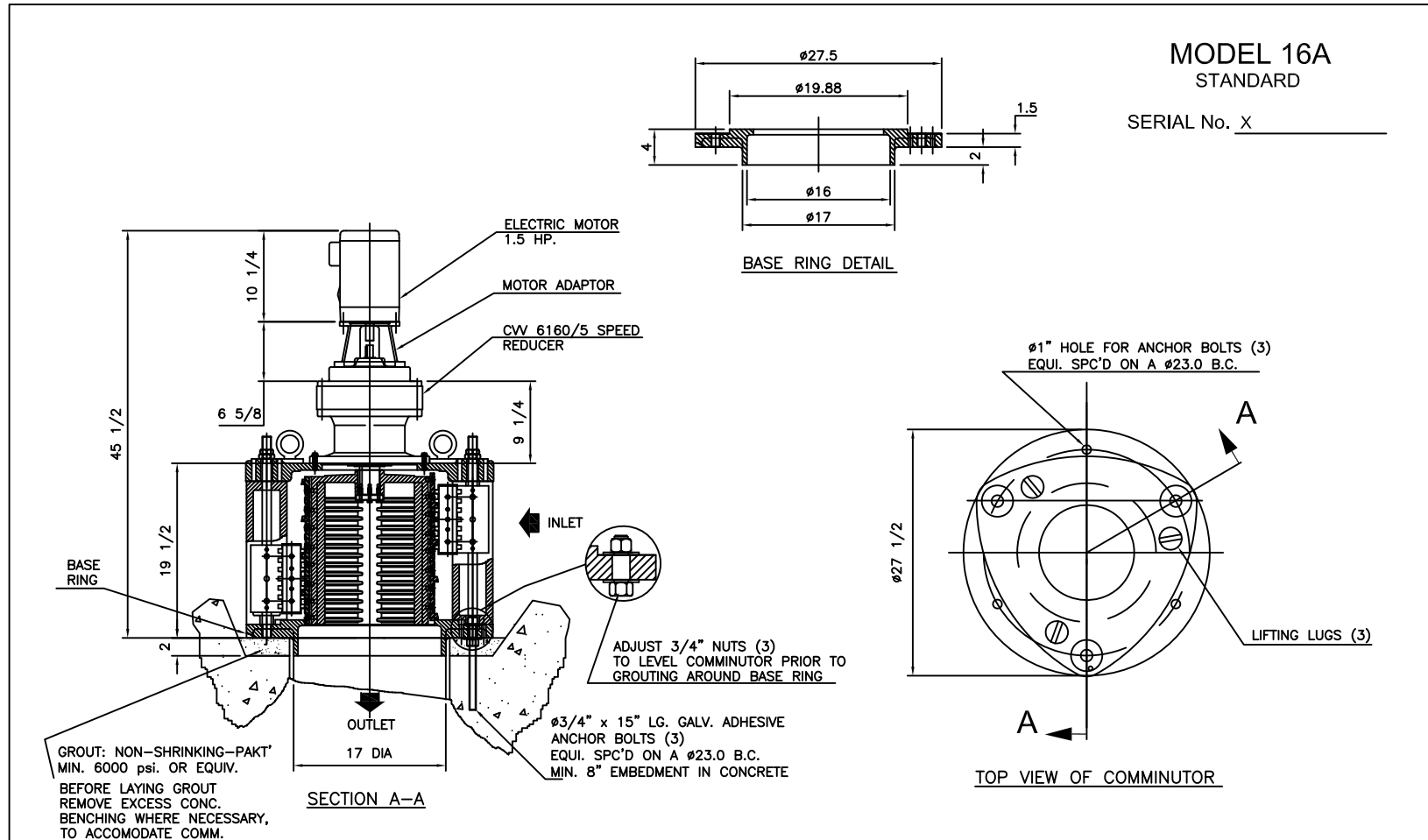

MATERIALS OF CONSTRUCTION & GENERAL ENGINEERING DATA							
HOUSING:	GREY IRON	CAPACITY:	3.5 MGD (US) / 13200 m ³ /day	INLET AREA:	202 SQ IN	1303 cm sq	
DRUM (SCREEN):	DUCTILE IRON (ASTM 536 GRADE 60-45-18)	DRUM SPEED:	30 RPM	OUTLET AREA:	121 SQ IN	780.6 cm sq	
SHEAR BARS:	AISI-A2 HIGH ALLOY TOOL STEEL	ROTATION:	CLOCKWISE	DRUM DIAMETER:	14.5 IN	36.8 cm	
CUTTING BARS:	AISI-01 TOOL STEEL REVERSIBLE	SLOT WIDTH:	.470 IN / 12 mm	WEIGHT:	750 LB	340 kg	
HARDWARE & FASTENERS:	304 STAINLESS STEEL	No. OF SLOTS:	56				
MOTOR MANUFACTURER:	BALDOR	POWER:	1 / 3 / 60	RPM:	1750	REDUCER:	SM - CYCLO
STYLE:	TEFC	HP:	1.5	KW:	1.12	FRAME:	145 TC
				FLANGE:	'C'	RATIO:	59:1
						RATING:	7.72 HP
						MODEL:	V6160

G.E.T. INDUSTRIES INC.

get@grindhog.com
www.grindhog.com
1 (877) 213-7418

TOLERANCES:	INFO.	SCALE	NTS
DECIMAL:	INFO.	DRAWN BY	G.P.
FRACTIONAL:	INFO.	APPROVED BY	W.D.M.
ANGULAR:	INFO.		
DATE	FILE NO.	DWG. NO.	REV.
MAR, 2012		6 0200	