



MODEL 10LS SPECIFICATION

1.0 General Specifications

There will be furnished one (1) only Grind Hog™ Model 10LS Comminutor as manufactured by G.E.T. Industries, Inc. Rotation shall be in a clockwise (standard) / counter-clockwise (optional) direction.

1.1 Design Criteria

The comminutor shall be designed to handle the flows indicated below, within the head loss noted.

- (a) hydraulic capacity 1.2 MGD (4500m³/day)
- (b) satisfactory operation shall occur under conditions of zero flow
- (c) head loss at peak flow shall not exceed 10 inches (254 mm)
- (d) design shall be such that the flow enters the size reduction and screening device horizontally and exits vertically downward to facilitate the flushing of solids

1.2 Casing and Curb Ring

Shall be:

- (a) of heavy-duty construction and of high quality cast iron
- (b) machined flat and complete with three (3) holes for anchor bolts
- (c) of the open type allowing free access for complete cutting bar and shear bar mechanism maintenance and inspection without dismantling the unit

1.3 Rotating Drum Screen

- (a) heavy-duty Cast Ductile Iron ASTM 536, grade 60-45-18

1.4 Cutting Elements

- (a) replaceable shear bars constructed of high-quality A2 tool-steel shall be attached to the rotating drum. Each shear bar shall be machined from solid bar stock, surface ground to establish exact tolerances
- (b) stationary cutting bars (3), shall be of high-quality 01 tool steel hardened to a minimum of 56 Rockwell C, and shall be reversible, allowing for four (4) sets of cutting edges prior to sharpening or replacement
- (c) all submerged fasteners shall be of stainless steel

1.5 Motor

Immersible 1 1/2 Hp. Motor, 1750 RPM, _____ volt, _____ phase, _____ cycle, suited to periodic submergence. Power cable length 25 ft. (7.6 m).

1.6 Drive Arrangement

- a) the motor shall be close-coupled to a speed reducer drive, a heavy duty planetary gear of the totally enclosed non-vented type suitable for total submergence during emergencies
- b) double seals on the output shaft shall ensure flood-proof operation through a reduction ratio of 35:1

G.E.T. INDUSTRIES INC.

Toll Free: 877-213-7418 Email: get@grindhog.com Web: www.grindhog.com

SPECIFICATION cont'd...



- c) the cycloidal reducer shall be capable of withstanding shock loads to 500% of its mechanical rating of 4.27 Hp. and be warranted for two (2) years
- d) the drive shall have a minimum full load efficiency of 90% and be pre-lubricated with grease, requiring routing maintenance every 500 to 1,000 hours

A) 'KWIK-LIFT' WET WELL REMOVAL SYSTEM

The Comminutor shall be equipped with a slide rail system which will allow the Grind Hog™ to be removed without entering the wet well. The guide rails shall be 304 schedule 40 stainless steel pipe, 1.5 inches in diameter, and shall be of adequate length as shown on the drawings. Guide rail support shall be 304 stainless steel and shall be mounted to the wet well wall. All attaching hardware shall be of stainless steel and shall be supplied by the contractor.

G.E.T. INDUSTRIES INC.

Toll Free: 877-213-7418 Email: get@grindhog.com Web: www.grindhog.com

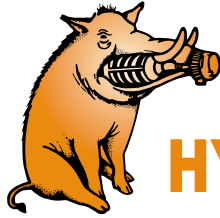

Grind Hog™

HYDRAULIC DATA SHEET IN-CHANNEL MODEL 10L

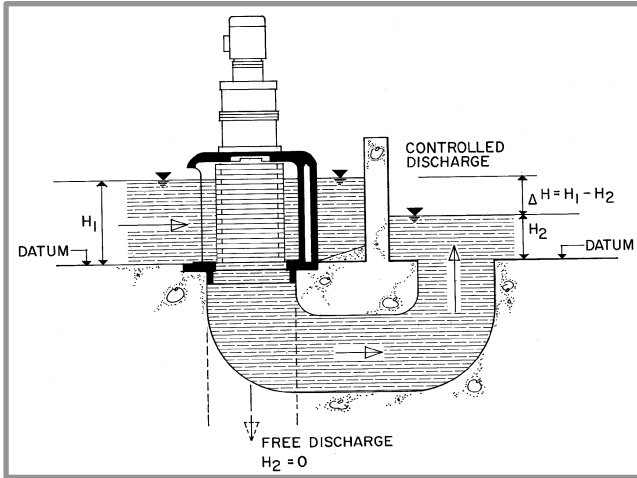

GENERAL DATA

Capacity	0-1.2 MGD (US)	0-4500 m ³ /day
Drum Diam.	9.4 in	23.9 cm
Inlet Area	97 in ²	625.8 cm ²
Outlet Area	45 in ²	290.3 cm ²
Slot Width	0.470 in	12 mm

HYDRAULIC PERFORMANCE CURVE

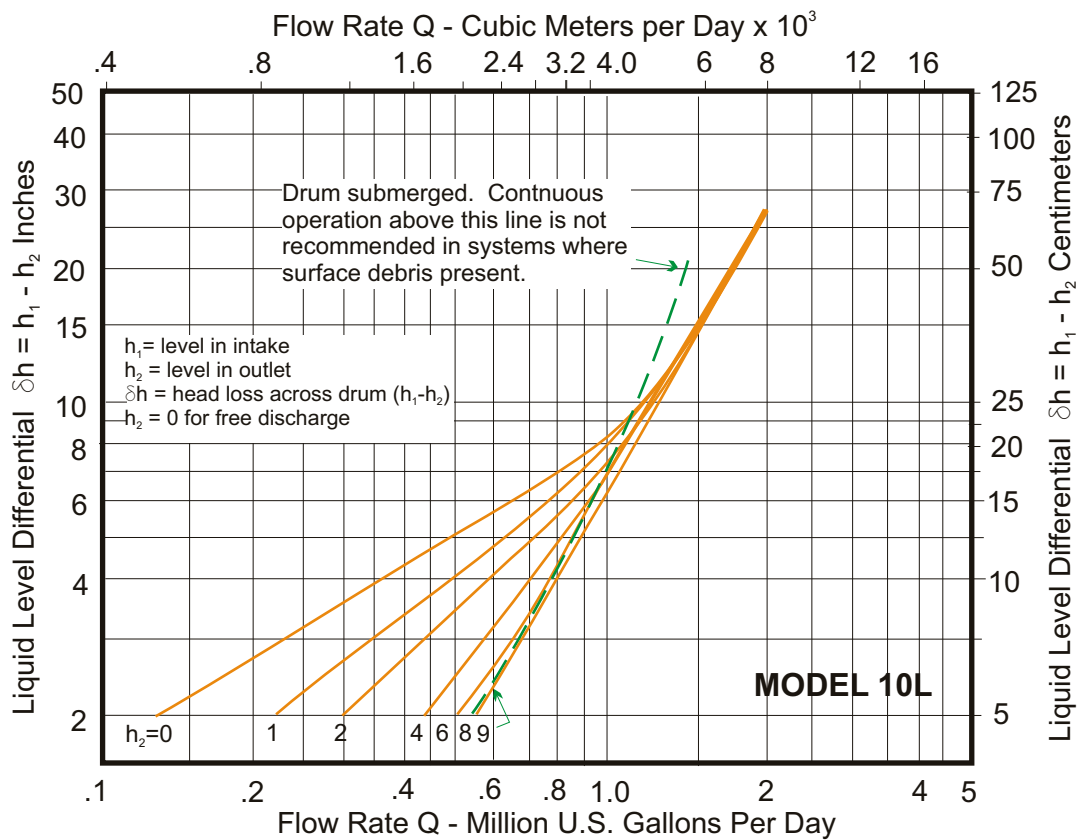



IN-CHANNEL MODEL 10L cont'd...

DESIGN FEATURES

SM-CYCLO® SPEED REDUCERS

- HIGHEST OVERLOAD CAPACITY FOR FREQUENT STOP-START AND SEVERE REVERSING
- SMOOTH, SILENT OPERATION
- EXCEPTIONAL LIFE

Torque transmitting parts roll, don't grind. There is no sliding friction, so output torque/input horsepower efficiency approaches 95%.

STATIONARY CUTTING BAR

- REVERSIBLE-SPARE STANDARD EQUIPMENT
- A2 HIGH QUALITY TOOL STEEL
- HIGH RESISTANCE TO WEAR

VERTICAL "FREE"
OR
"CONTROLLED"
DISCHARGE

CAST DUCTILE IRON SEWAGE SCREEN

- LONG LIFE UNDER ABRASIVE CONDITIONS

ROTATING SHEAR BAR ASSEMBLY

- MACHINED FROM SOLID BARSTOCK
- PRECISE TOLERANCES MAINTAINED.

SUBMERGED FASTENERS OF STAINLESS STEEL

HEAVY DUTY CAST IRON CONSTRUCTION

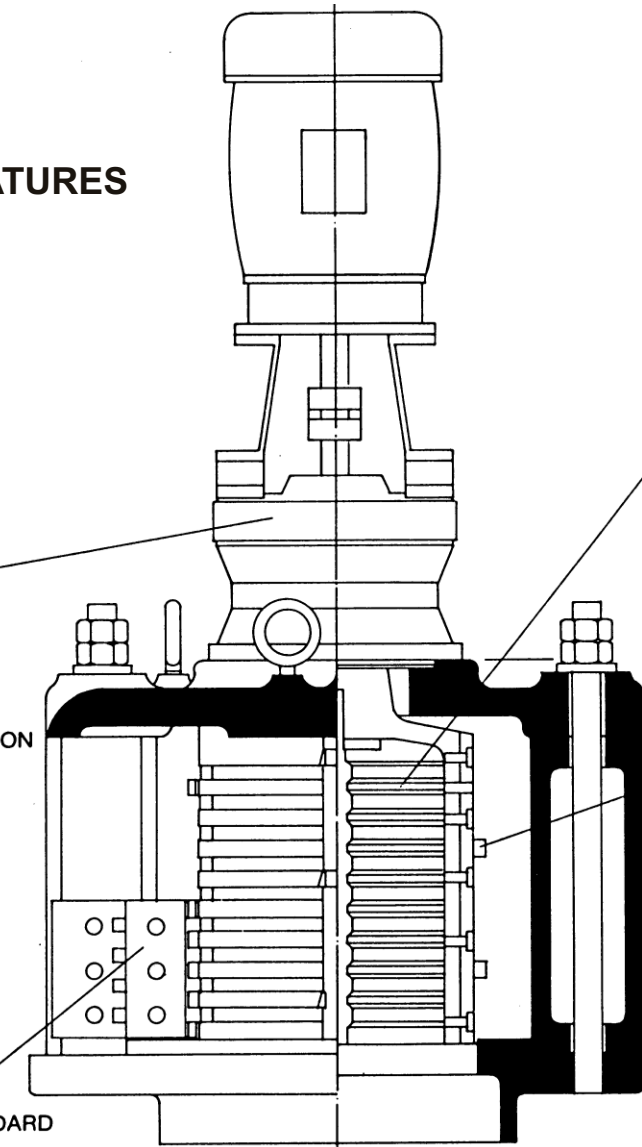

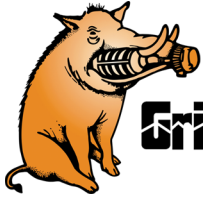

Grind Hog

MECHANICAL DETAIL

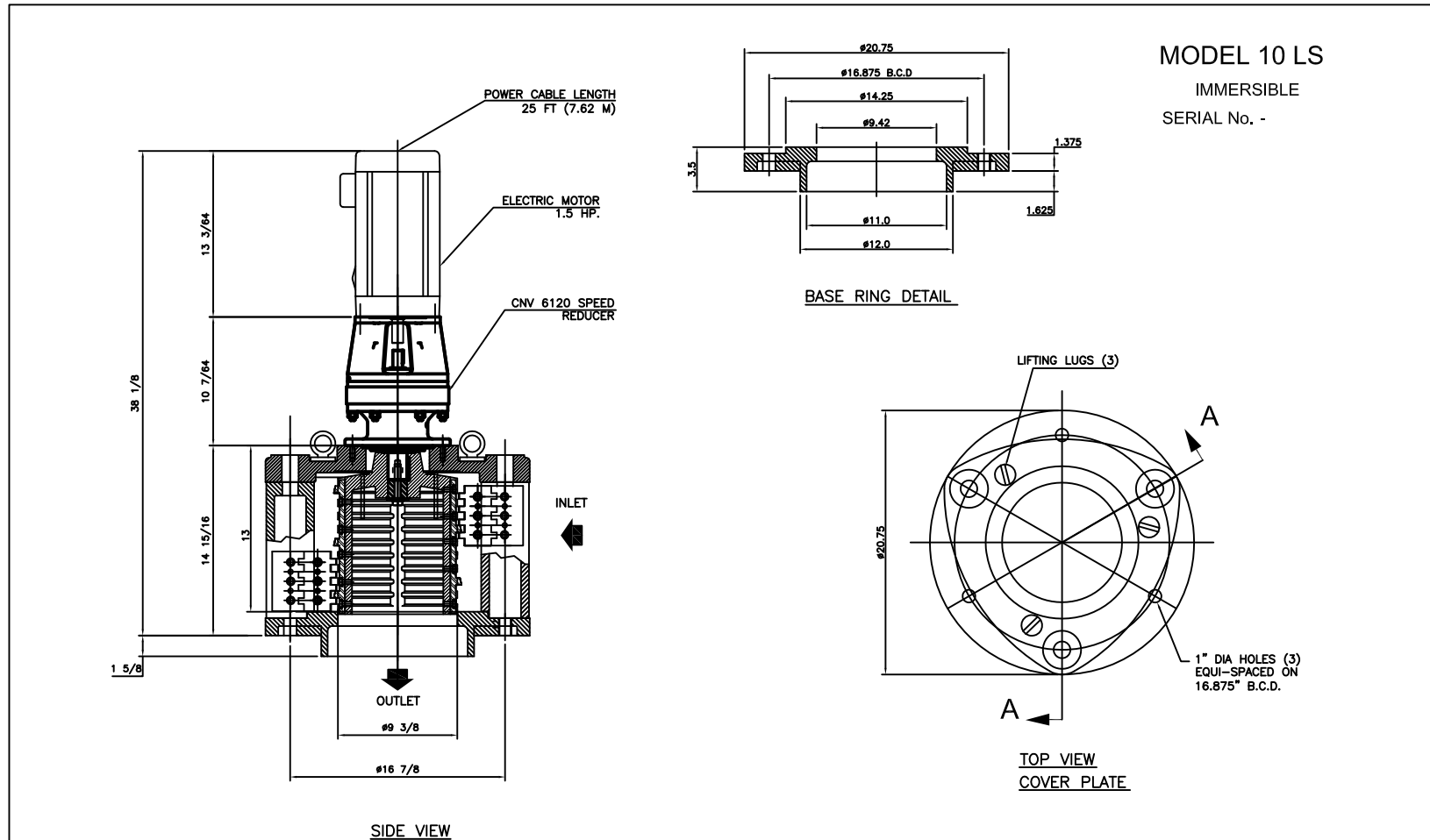

MODEL 10 LS
IMMERSIBLE
SERIAL No. -

MATERIALS OF CONSTRUCTION & GENERAL ENGINEERING DATA							
HOUSING:	GREY IRON	CAPACITY	1.2 MGD (US) / 4500 m3/day	INLET AREA	97 SQ IN	626 cm sq	
DRUM (SCREEN):	DUCTILE IRON (ASTM 536 GRADE 60-45-18)	DRUM SPEED	50 RPM	OUTLET AREA	45 SQ IN	290 cm sq	
SHEAR BARS:	AISI-A2 HIGH ALLOY TOOL STEEL	ROTATION	CLOCKWISE	DRUM DIAMETER	9.4 IN	23.9 cm	
CUTTING BARS:	AISI-H1 TOOL STEEL REVERSIBLE	SLOT WIDTH	.470 IN / 12 mm	WEIGHT	450 LB	204 kg	
HARDWARE & FASTENERS:	304 STAINLESS STEEL	No. OF SLOTS	36				
MOTOR MANUFACTURER:	BALDOR	POWER:	- / - / -	RPM:	1750	REDUCER:	SM - CYCLO
						MODEL:	V6120 HS
STYLE: IMMERSIBLE	HP: 1.5	KW: 1.12	FRAME: 56C	FLANGE: 'C'	RATIO: 35:1	RATING: 4.27 HP	

G.E.T. INDUSTRIES INC.
 get@grindhog.com
 www.grindhog.com
 1 (877) 213-7418

TOLERANCES	INFO	SCALE	NTS
DECIMAL	INFO	DRAWN BY	G.P.
FRACTIONAL	INFO	APPROVED BY	W.D.M.
ANGULAR	INFO		
DATE	FILE NO.	DWG. No.	REV.
DEC. 2013		6 0180	