



MODEL 24ASX T/S SPECIFICATION

1.0 General Specifications

There will be furnished one (1) only Grind Hog™ Model 24ASX T/S Comminutor as manufactured by G.E.T. Industries, Inc. Rotation shall be in a clockwise direction

1.1 Design Criteria

The comminutor shall be designed to handle the flows indicated below, within the head loss noted.

- a) hydraulic capacity 10 MGD (37,800m³/day)
- b) satisfactory operation shall occur under conditions of zero flow
- c) head loss at peak flow shall not exceed 20 inches (508 mm)
- d) design shall be such that the flow enters the size reduction and screening device horizontally and exits vertically downward to facilitate the flushing of solids

1.2 Cover Plate

Shall be:

- a) of heavy-duty construction and of high quality cast iron
- b) fitted with 4 position lock down arrangement, and 2 alignment holes for repositioning following service
- c) located on, and positioned by wall mounted supports allowing for ease of removal for inspection and maintenance.

1.3 Rotating Drum Screen

- a) heavy-duty Cast Ductile Iron ASTM 536, grade 60-45-18

1.4 Cutting Elements

- a) replaceable shear bars constructed of high-quality A2 tool-steel shall be attached to the rotating drum. Each shear bar shall be machined from solid bar stock, surface ground to establish exact tolerances
- b) stationary cutting bar, shall be of high-quality 01 tool steel hardened to a minimum of 56 Rockwell C, and shall be reversible, allowing for four (4) sets of cutting edges prior to sharpening or replacement
- c) all submerged fasteners shall be of stainless steel

1.5 Motor

Submersible, Explosion-proof 1.5 Hp. (1.12 kw), 1750 RPM _____ volt, 3 phase, 60 HZ, rated for continuous-in-air or submerged in sewage service. Power control cable of 25 ft (7.6 m) included. Class 1, Group C and D, Division 1 Hazardous locations. The motor shall feature:

- **Frame** - rugged cast iron ASTM type A-48, class 30
- **Hardware** - 316 stainless steel

G.E.T. INDUSTRIES INC.

Toll Free: 877-213-7418 Email: get@grindhog.com Web: www.grindhog.com

SPECIFICATION cont'd...



- **Stator Insulation** - specially treated class "F" and "H" non-hydroscopic insulation with multiple dips and brakes. Phase insulation included for inverter duty
- **Rotor** - die cast aluminum, dynamically balanced. Exceeds NEMA limits per MGI - 12.06
- **Shaft** - high strength 416 stainless steel
- **Bearings** - specially adapted for vertical assembly. Both upper and lower bearings are pre-packed and sealed for life with special high temperature grease
- **Cable Entry System** - epoxy sealed butt spliced connect for non-wicking cable entry design
- **Moisture System** - two wire /two probe monitoring system constantly monitors oil chamber and stator housing for moisture
- **Seals** - tandem (dual) shaft seal system working independent of each other. Designed to withstand 100 PSI at all seal locations

1.6 Drive Arrangement

- a) the motor shall be close-coupled to a speed reducer drive, a heavy duty planetary gear of the totally enclosed non-vented type suitable for total submergence during emergencies
- b) double seals on the output shaft shall ensure flood-proof operation through a reduction ratio of 59:1
- c) the cycloidal reducer shall be capable of withstanding shock loads to 500% of its mechanical rating of 11.1 Hp. and be warranted for two (2) years
- d) the drive shall have a minimum full load efficiency of 90% and be pre-lubricated with grease, requiring routine maintenance every 500 to 1,000 hours

1.7 "Toilet Seat" Channel Mounting System

Shall consist of a box style structure fabricated of 304 Stainless Steel dimensioned to suit the existing channel and supported from above for ease of installation

G.E.T. INDUSTRIES INC.

Toll Free: 877-213-7418 Email: get@grindhog.com Web: www.grindhog.com

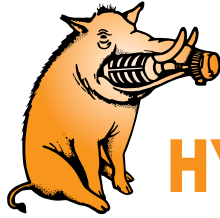

Grind Hog™

HYDRAULIC DATA SHEET IN-CHANNEL MODEL 24ASX T/S

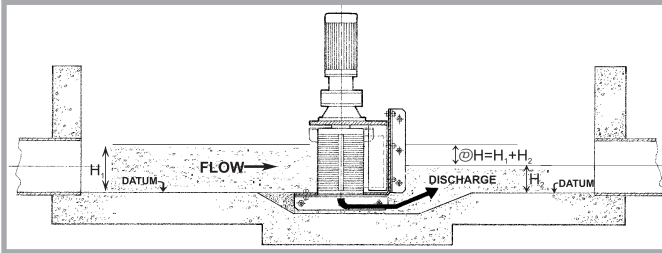

GENERAL DATA

Capacity	0-10 MGD (US)	0-37800 m ³ /day
Drum Diam.	22.5 in	57.2 cm
Inlet Area	526 in ²	3393 cm ²
Outlet Area	324 in ²	2090 cm ²
Slot Width	0.470 in	12 mm

HYDRAULIC PERFORMANCE CURVE

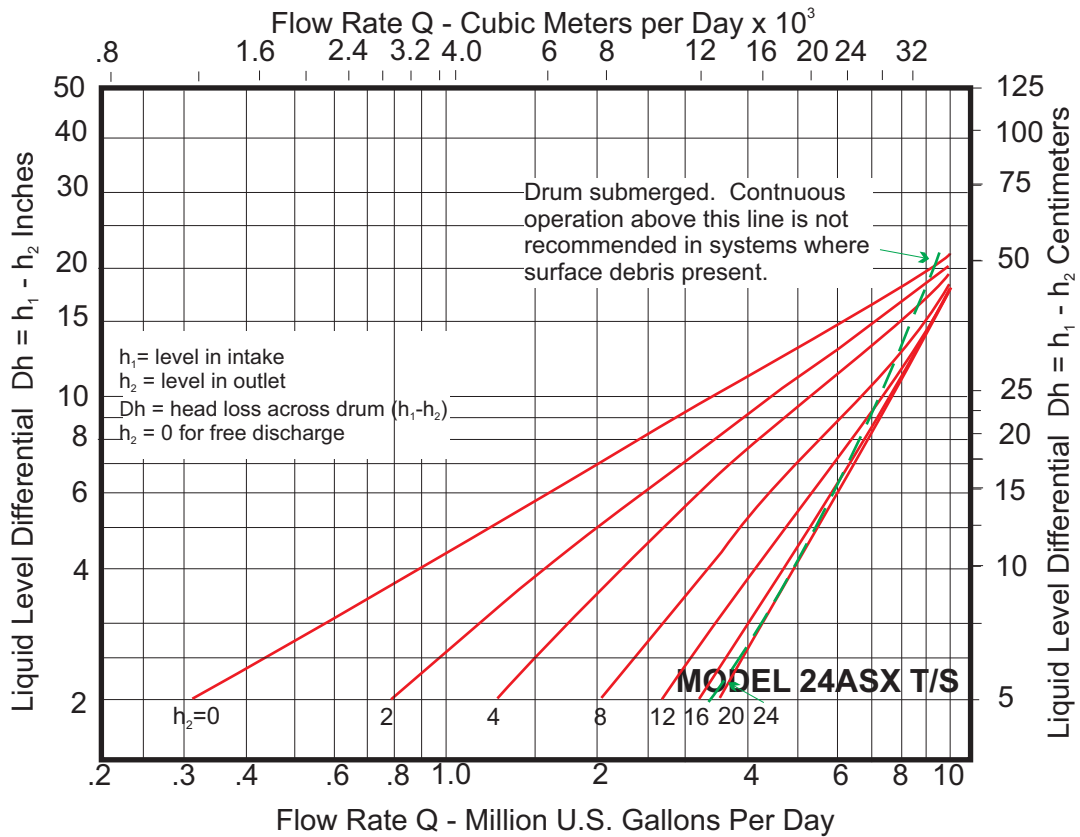

G.E.T. Industries Inc.

Toll Free: (877) 213-7418

E-mail: get@grindhog.com ♦ Web: www.grindhog.com



IN-CHANNEL MODEL 24ASX T/S cont'd...

DESIGN FEATURES

SUMITOMO SM-CYCLO SPEED REDUCER 6000 SERIES

- HIGHEST OVERLOAD CAPACITY FOR FREQUENT STOP-START AND SEVERE REVERSING
 - SMOOTH, SILENT OPERATION
 - EXCEPTIONAL LIFE
- Torque transmitting parts roll, don't grind.
There is no sliding friction, so output torque/input horsepower efficiency approaches 95%

STATIONARY CUTTING BAR

- REVERSE-SPARE STANDARD EQUIPMENT
- A2 HIGH QUALITY TOOL STEEL
- HIGH RESISTANCE TO WEAR

CAST DUCTILE IRON SEWAGE SCREEN

- LONG LIFE UNDER ABRASIVE CONDITIONS

ROTATING SHEAR BAR ASSEMBLY

- MACHINED FROM SOLID BARSTOCK
- PRECISE TOLERANCES MAINTAINED

SUBMERGED FASTENERS OF STAINLESS STEEL

HEAVY DUTY CAST IRON CONSTRUCTION

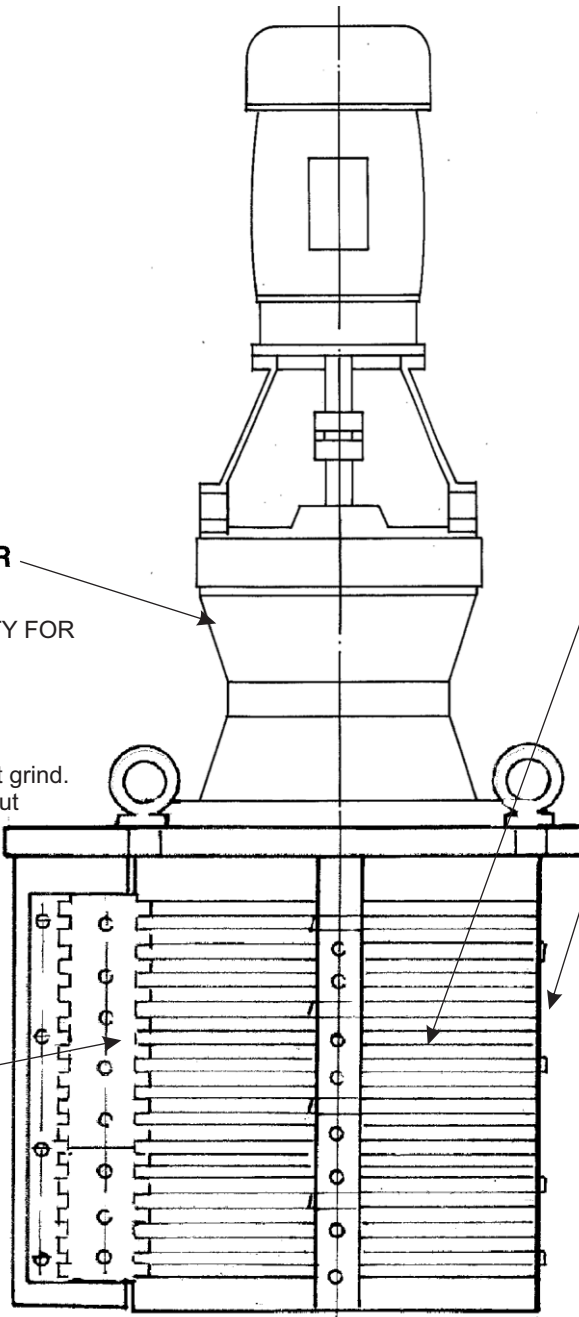



Grind Hog™

MECHANICAL DETAIL

MODEL 24ASX T/S
SER. No. _____

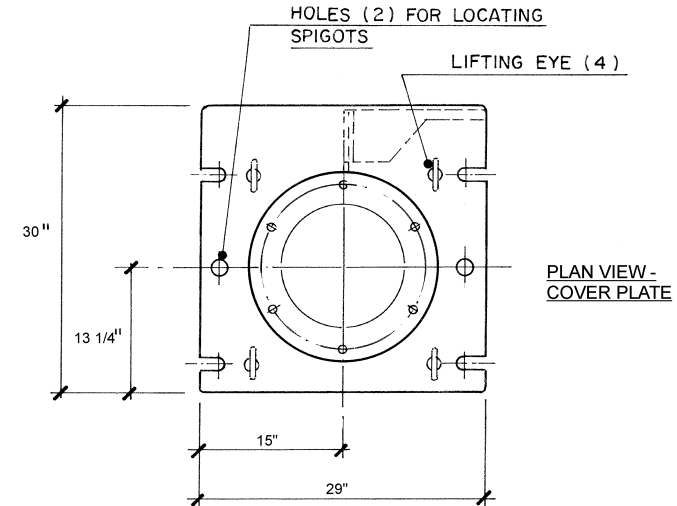
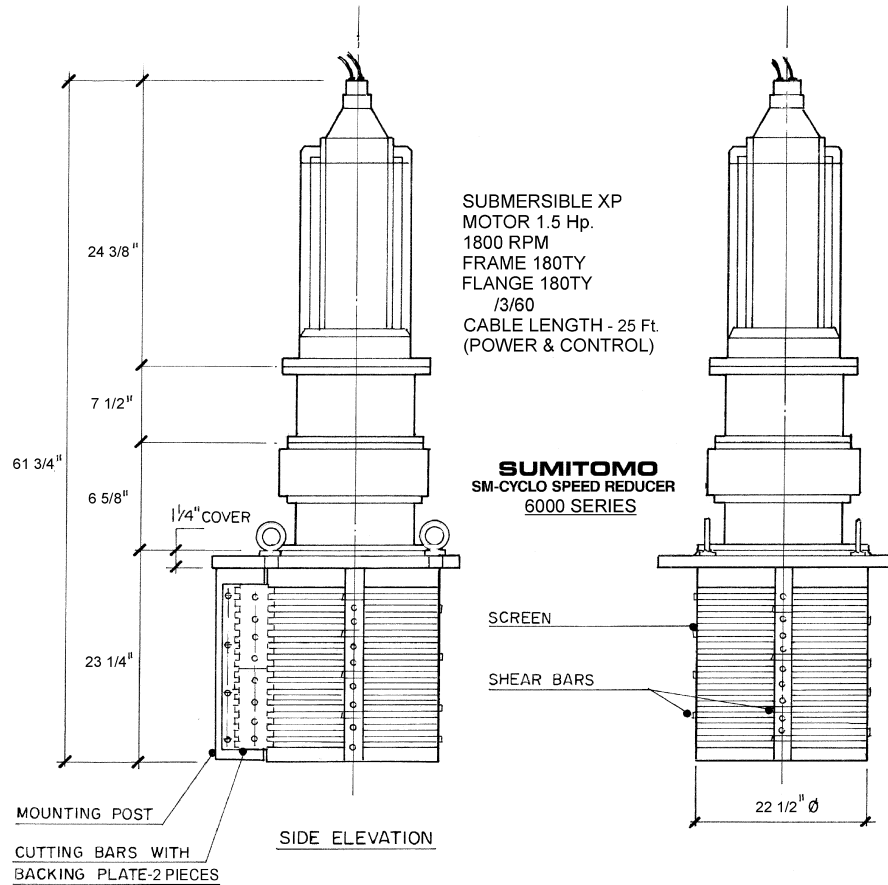

REVISIONS		BY	DATE	APP.
 G.E.T. INDUSTRIES INC. (877) 213-7418 www.grindhog.com				
TOLERANCES				SCALE
* DECIMAL				NTS
* FRACTIONAL				DRAWN BY
* ANGULAR				JW
* DATE	PROJECT NO.	DRAWING NO.	REV.	
		6 0286		

MATERIALS OF CONSTRUCTION & GENERAL ENGINEERING DATA					
HOUSING:	GREY IRON	CAPACITY:	10 MGD (US)/37800 m ³ /day	INLET AREA:	526 sq in 3393 cm sq
DRUM (SCREEN):	DUCTILE IRON (ASTM 536 GRADE 60-45-18)	DRUM SPEED:	30 RPM	OUTLET AREA:	324 sq in 2090 cm sq
SHEAR BARS:	AISI-A2 HIGH ALLOY TOOL STEEL	ROTATION:	CLOCKWISE	DRUM DIAMETER:	22.5 in 572 cm
CUTTING BARS:	AISI-01 TOOL STEEL REVERSIBLE	SLOT WIDTH:	0.470 in / 12 mm	WEIGHT:	lb kg
HARDWARE & FASTENERS:	304 STAINLESS STEEL	NO OF SLOTS:	76		
MOTOR MANUFACTURER:		POWER:	/ /	RPM:	1750
STYLE: SUB XP C-1A	HP: 1.5	KW: 2.24	FRAME: 180TY	FLANGE: 180TY	RATIO: 59:1
				RATING:	11.1 HP
				SM-CYCLO REDUCER MODEL:	V6170



**Grind
Hog**

HORIZONTAL FLOW

RETROFIT ALTERNATIVE

“TOILET SEAT BOX STYLE” DROP IN REPLACEMENT

PROJECT: _____

ANTICIPATED PEAK FLOW: _____

EXISTING CHANNEL:

Width (w): _____

Depth (d): _____

Underdrain Clearance (c): _____

MOTOR REQUIREMENTS:

Power: _____ / _____ / _____

Enclosure: _____

Replaceable wear ring for extended life

Supported from above on the channel walls, eliminating the requirement for any submerged anchorage

Fabricated from 304 Stainless Steel to suit existing channel dimensions

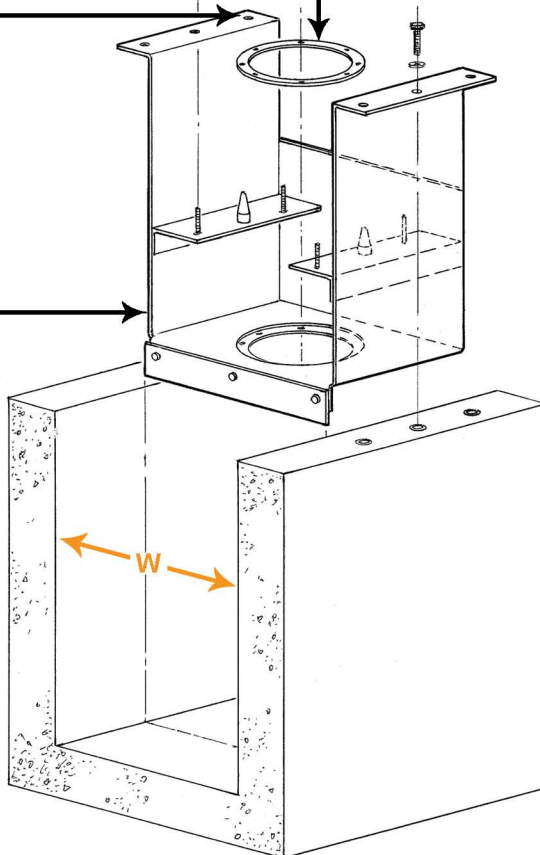
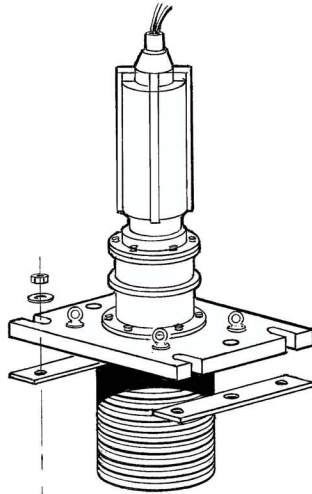

REPLACING

Barminutor

Infilco Degremont

Clow Aer-O-Flo

Muffin Monster

Franklin Miller-Diminutor

Worthington

.....Among others

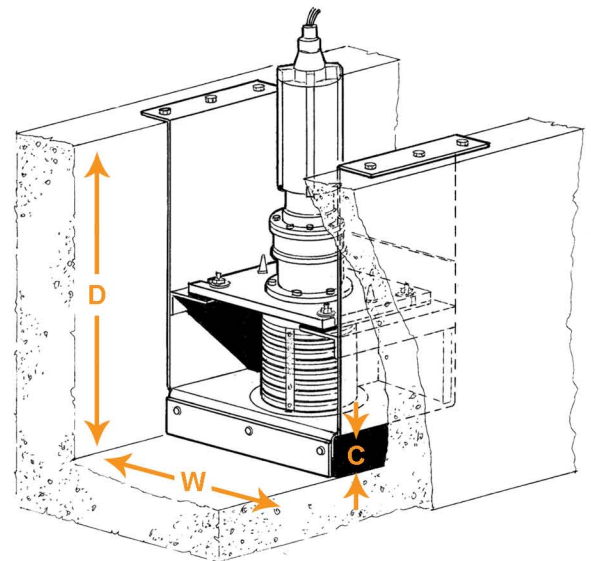

HORIZONTAL FLOW



Customized to suit each application

ORIGINAL CHANNEL

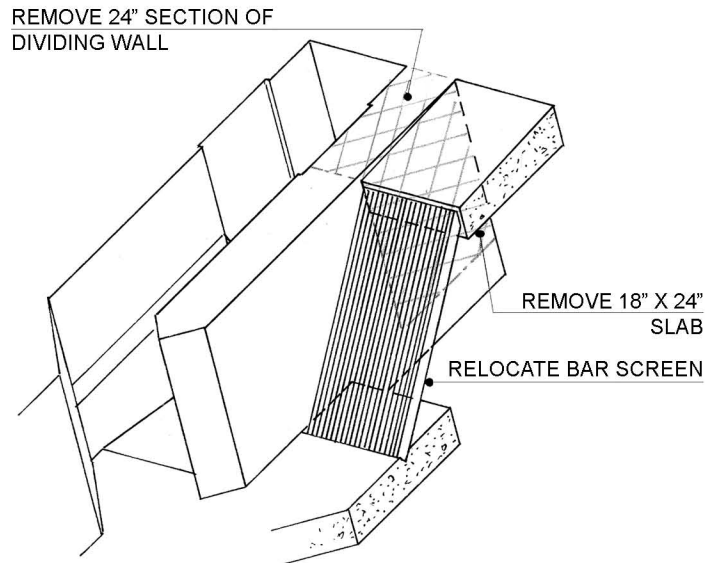

PROPOSED CHANGES

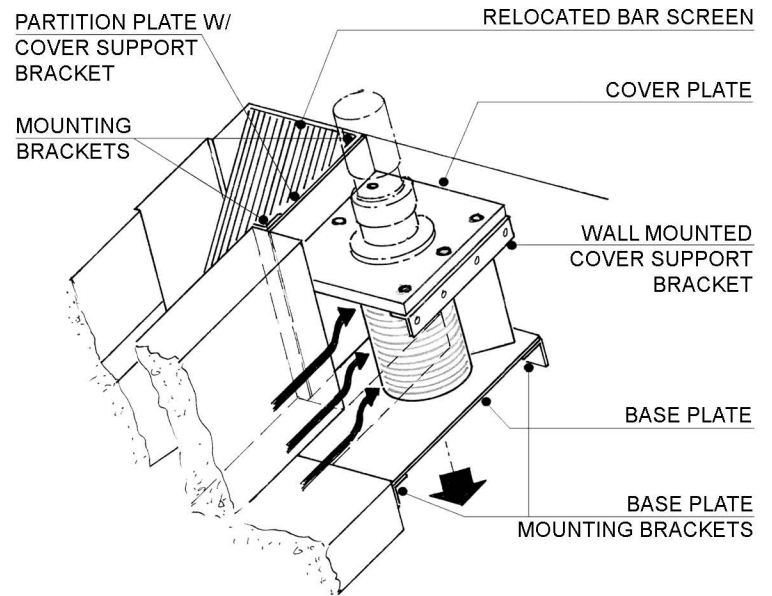

Original
Worthington 15-5



Custom Fabricated
Basin



16 ASX T/S



Custom Fabricated Basin
& 16ASX T/S
Ready for Shipment

G.E.T. INDUSTRIES INC.

Toll free: (877) 213-7418

Email: get@grindhog.com

Web: www.grindhog.com